



AdaptaSpan

A Better Way

Toronto

Regina

Vancouver

1-866 635 8818

Height Access Solutions
safesmartaccess.ca

 SafeSmart

ADAPTASpan

There is an increasing global demand on construction and infrastructure projects to provide safer and more efficient egress ways for site personnel.

SafeSmart Is proud to offer our engineered aluminum modular bridging system: **AdaptaSpan**.

This modular bridging system has rapidly become a popular option for projects that require engineered, safe, and cost-effective access solution. AdaptaSpan bridge modules are available in 1m, 2m, and 3m long sections which can be bolted/connected end-to-end to create large walkways and bridges spanning up to 21M in length.

SafeSmart's AdaptaSpan bridging system is the optimal answer for temporary bridging over excavations, creeks, trenches, and to your tower cranes.

Flexible: The AdaptaSpan system provides safe & streamlined access across trenches, canals, footpaths and worksites.

Efficient: 1.2mW allows for two-way access. Crane lift attachments allow for simple redeployments as site needs change.

Modular: Join modules together to create a clear span bridge up to 21mL. Module sizes include: 1mL, 2mL, and 3mL.

Tower Crane Access: Attachments available to allow AdaptaSpan to connect to tower cranes.



ADAPTASPAN

MODULES

Code	Description	Measurements
210136	AdaptaSpan Modular Bridge	1m module x 1.2mW, 2.5kPa
210145	AdaptaSpan Modular Bridge	2m module x 1.2mW, 2.5kPa
210137	AdaptaSpan Modular Bridge	3m module x 1.2mW, 2.5kPa
210134	AdaptaSpan Modular Bridge Anchor Bracket	-
210135	AdaptaSpan Modular Bridge: Hinging End Ramp	0.7mL x 1.2mW
210129	AdaptaSpan Crane Lifting Lug	-

CRANE BRIDGE ATTACHMENTS

Code	Description	Measurements
210130	AdaptaSpan Tower Crane Access Adapter Frame	0.6mL x 1.2mW
210131	AdaptaSpan Modular Bolt-On Extra Height Guardrail - 1mL Pair	1mL
210132	AdaptaSpan Modular Bolt-On Extra Height Guardrail - 2mL Pair	2mL
210133	AdaptaSpan Modular Bolt-On Extra Height Guardrail - 3mL Pair	3mL
210138	AdaptaSpan Bolt On 200mm Swivel/Braked Castors Pair of LH & RH	200mm
210139	AdaptaSpan Modular Bolt On Height Adjustment Pack Pair	0-0.8mH Vertical Adjustment
210146	AdaptaSpan Bridge Tower Crane Access 2mH Entry/Exit Swing Gate with Mesh	2mH x 1.2mW
210147	AdaptaSpan Tower Crane Access Anti-Climb Wings & Panel	2.5mH x 2.23mW

NEED TO GO LONGER? CREATE A SPAN UP TO 21M

Code	Description	Measurements
210123	AdaptaSpan Accessories Brace Structure incl H/ware	-
210126	AdaptaSpan Accessories Guardrail Strongback	100 x 50 x 4mm RHS, 6.0mL with machined holes



ADAPTASPAN

COMPONENTS

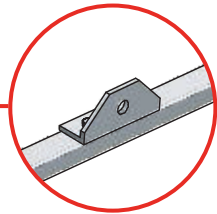
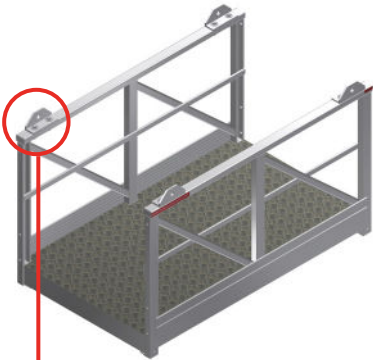

CRANE LIFTING LUGS

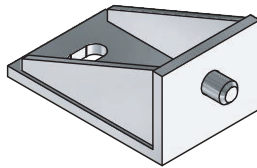
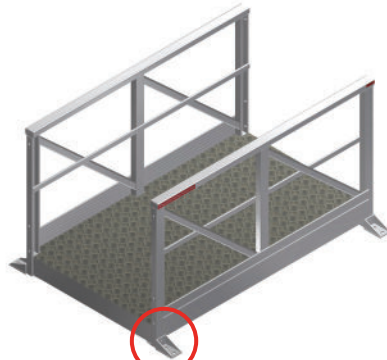

ANCHOR BRACKET

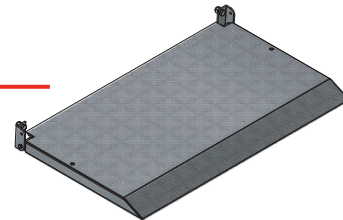
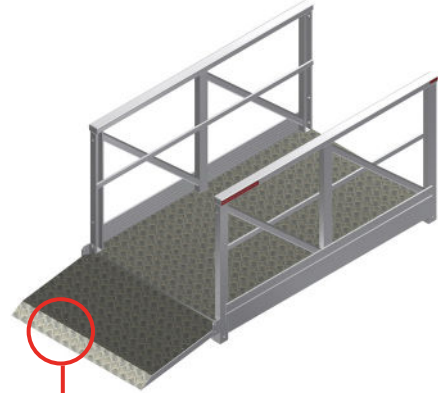

HINGING END RAMP

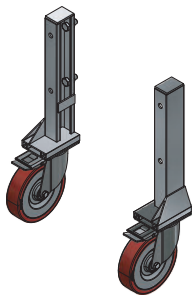
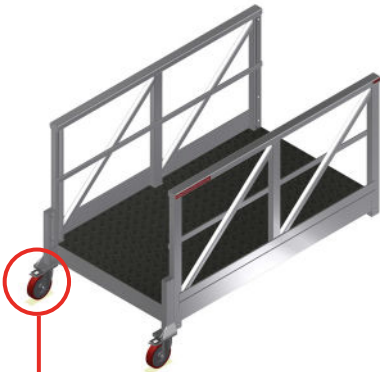

**BOLT-ON CASTORS
AND BRACKETS**

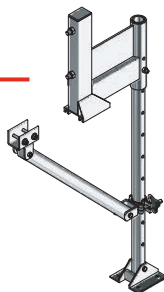
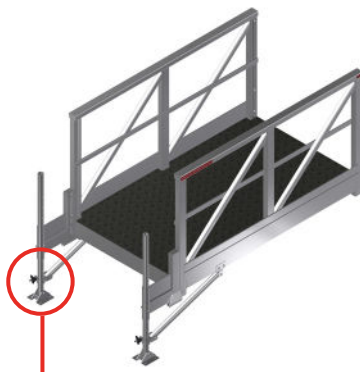

**BOLT-ON HEIGHT
ADJUSTABLE BRACKETS**

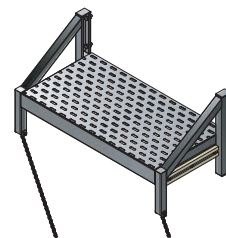
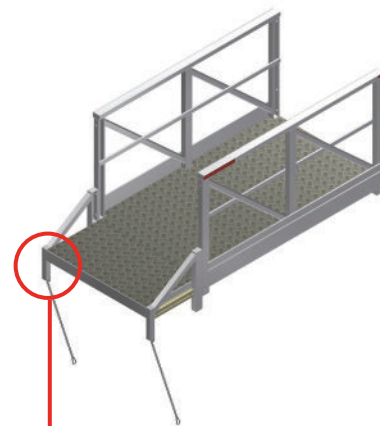

**TOWER CRANE ACCESS ADAPTER
FRAME**



ADAPTASPAN COMPONENTS

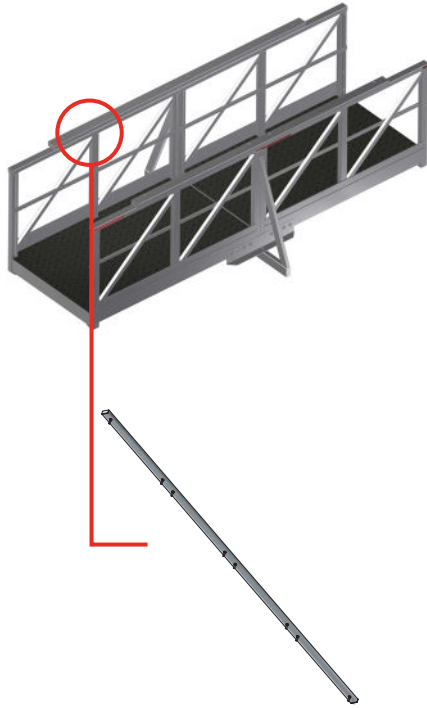

**GUARDRAIL
STRONGBACK**

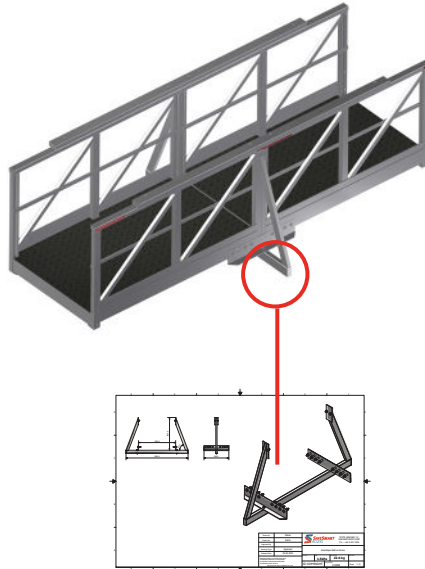

**BRACE STRUCTURE
INC H/WARE**

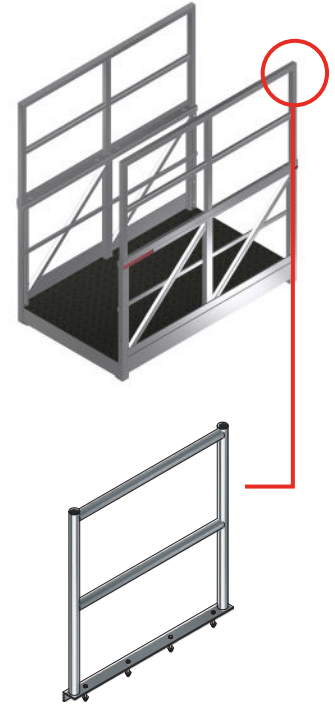

**MODULAR BOLT-ON EXTRA
HEIGHT GUARDRAIL PAIR**

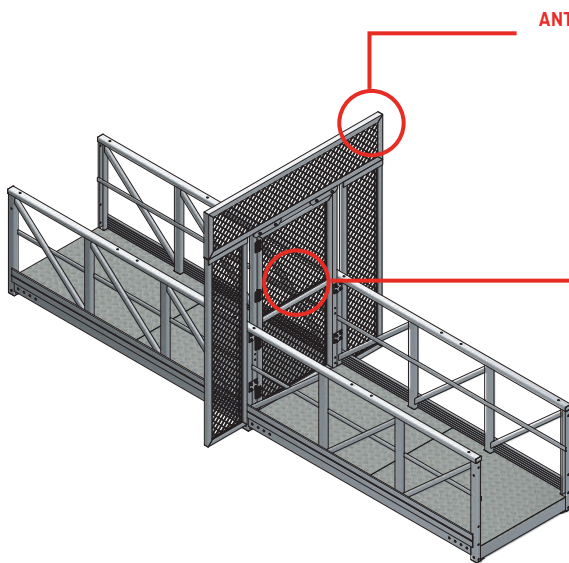

**ANTI-CLIMB WINGS &
PANEL**

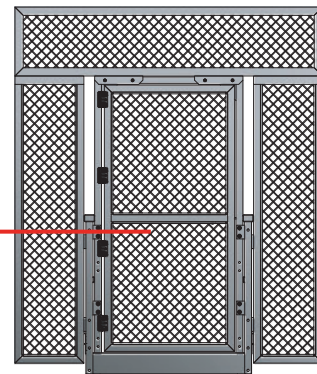

ENTRY/EXIT SWING GATE WITH MESH

ADAPTASPAN INDUSTRY APPLICATIONS

EFFICIENT SITE ACCESS



ADAPTASPAN INDUSTRY APPLICATIONS



Ladders

Mobile Scaffolding

Work Platforms

Stairs

Ramps & Walkways

Edge Protection

Custom Solutions

Proscat

Accessories

Aviation Access

ADAPTASPAN INDUSTRY APPLICATIONS



ADAPTASPAN INDUSTRY APPLICATIONS

CRANE BRIDGE





A Better Way™

 **SafeSmart**

Office Locations

Toronto ON | Regina SK | Vancouver BC

Height Access Solutions | www.safesmartaccess.ca